

TT-250 & TT-500 Tilting Turn-Tables

The model TT-250 & TT500 are two axes heavy duty, high accuracy tilting turntables specially designed for today's thermal spray applications.

Both turn tables are supplied in two versions:

1. Fully robot integrated as 7th and 8th axis, rotation/indexing and tilting/positioning
2. Standalone* with own controller, rotation and tiling only (no indexing, no positioning). The standalone version in non-standard.

All components selected for the tilting and rotation mechanism are of highest quality.

Turntable rotation and tilting axis

In the standard configuration, the rotation and tilting of the TT-250 & TT-500 are fully integrated as external axes of the robot (7th and 8th axis). These robot controlled turntables provide a high degree of flexibility. Coordinated motions of the robot arm and the turntable allow the spraying of essentially any complex surface. Movements and positions are programmed via the Robot teach pendant or off-line using robot simulation/development software.

The TT-250 and TT-500 can be integrated with various robots including: ABB, (other robot systems upon request)

Each axis is equipped with a high accuracy servomotor which is closed loop controlled. This provides highly accurate indexing and rotation. Further, it enhances work safety; one example of which is absolute rotation stop control in case of an emergency.

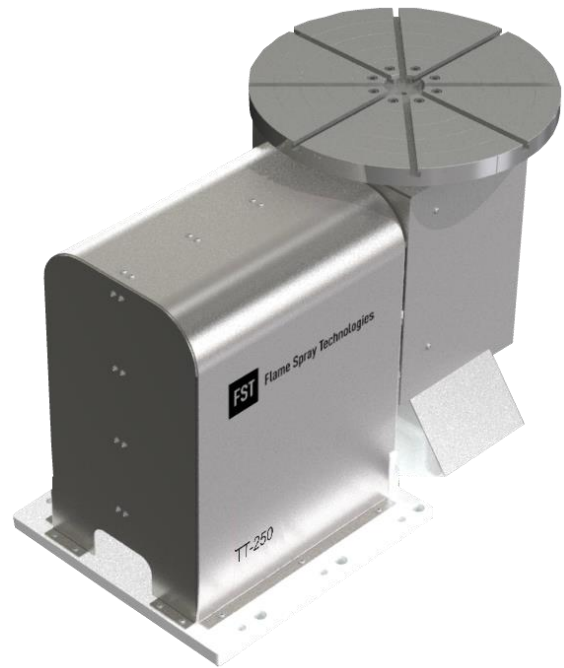

Tilting Turn-Table TT-250

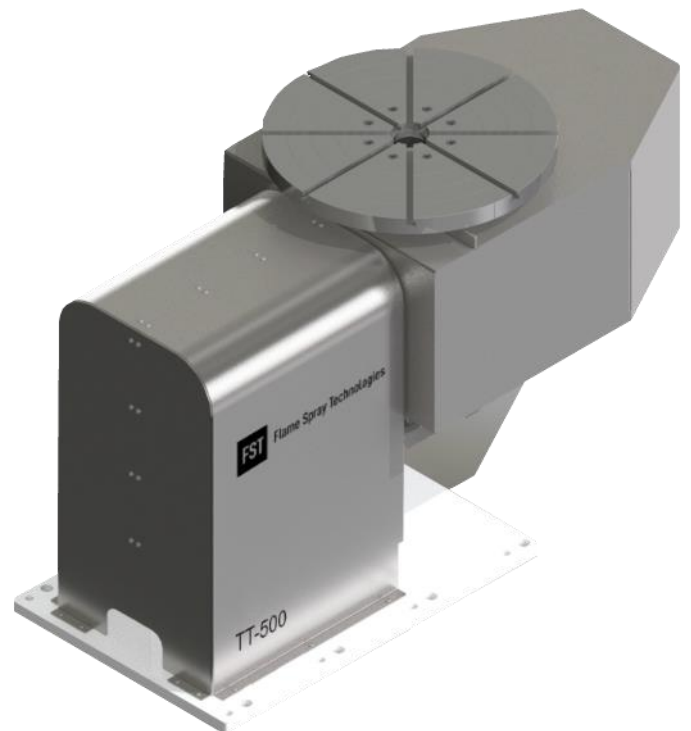

Tilting Turn-Table TT-500

* Standalone means: limited integration. e-stop integration.

Both turntable system controls include safety devices to monitor the rotation speed, faceplate position and tilting movement of a work piece during the coating process.

A zero speed sensor is used to monitor the rotational movement of the turntable during the spray process. In case of an unforeseen stop of the turntable, the control system will immediately stop the spray process and initiate the emergency shutdown mode. This feature prevents damage to the work piece by the process.

The turntable rotation axis provides two different operating modes. In both cases the movements and positions are programmed via the Robot.

Rotation mode:

In this mode the turntable rotates at a constant speed between 0 to 300 RPM. The rotation speed is closed loop controlled in this mode. The operator can program different speeds. The direction of rotation is programmable clockwise (CW) or counter clockwise (CCW).

Position mode:

In this mode the position of the faceplate is controlled and synchronized with the Robot as the 7th and 8th robot axis. The turntable faceplate can be moved/ positioned to any desired position.

Specifications

Descriptions	TT-250	TT-500
Load Capacity – Horizontal (0°)	250kg	500kg
Load Capacity – Vertical (90°) Mass inertia product	125kg (center of gravity at 500mm) Maximal 20 kgm ²	250kg (center of gravity at 500mm) Maximal 45 kgm ²
RMP range	0 – 300 (±1 rpm)	0 – 300 (± 1 rpm)
Direction of Rotation	CW/CCW	CW/CCW
Tilting Positioning	-90° +90° Accuracy repeatability	<±0.1° Accuracy repeatability
Rotary Table Positioning	Accuracy repeatability	<±0.1° Accuracy repeatability
Face plate	Hardened Steel or High Strength Aluminum (optional) Diameter: 600mm Thickness: 35mm 8 T-slots and hollow shaft, Ø50 mm for internal cooling	Hardened Steel or High Strength Aluminum (optional) Diameter: 600mm or 800mm (optional) Thickness: 35mm 8 T-slots and hollow shaft, Ø70 mm for internal cooling
Zero speed sensor	Yes	Yes
Total Weight	780 kg	850 kg
Optional		
1. High Speed Spindles Ad-On	3 spindles, 0-1500 rpm, 5kg	3 spindles, 0-1500 rpm, 5kg
2. Multi Spindles Ad-On	6 spindles, 0-300 rpm, 20kg	6 spindles, 0-300 rpm, 20kg

TT-250 Tilting Turn-Table

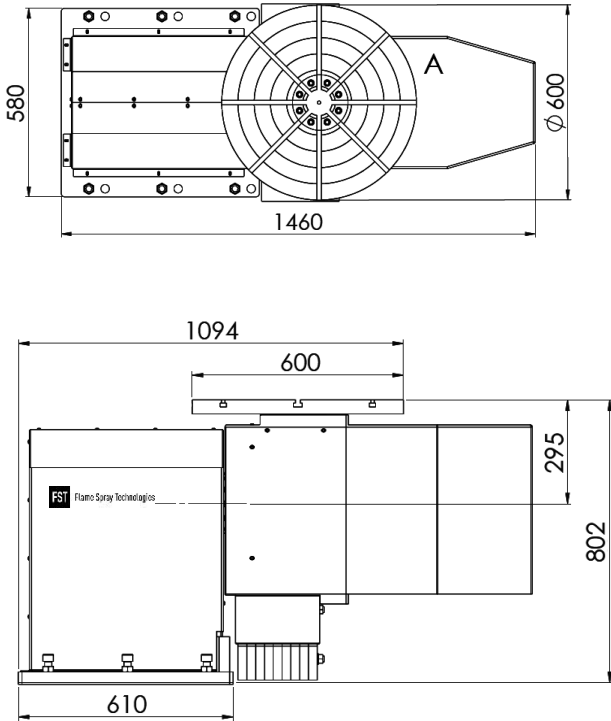

Max. 250 kG load (by horizontal position).
Load must be balanced.

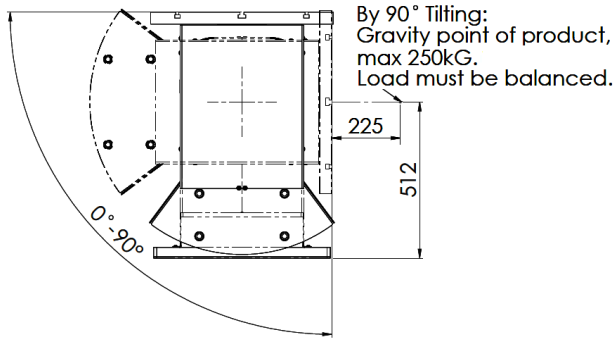

TT-500 Tilting Turn-Table

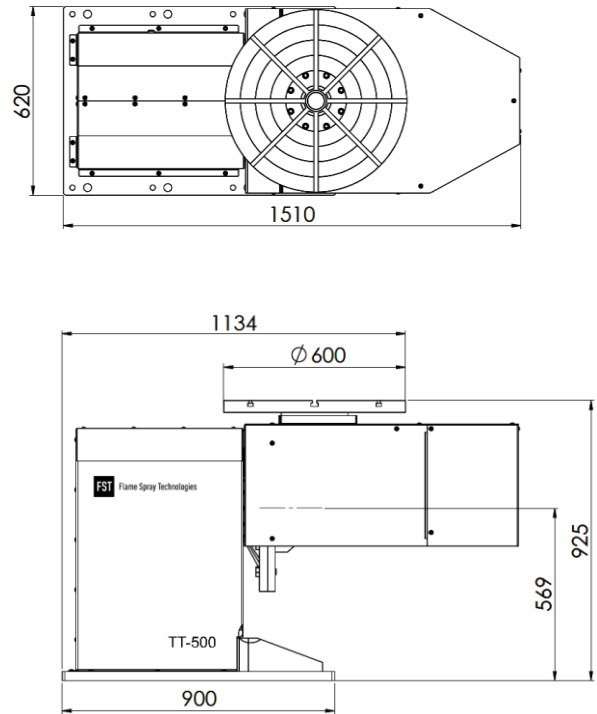

Max 500 kG Load (by horizontal position).
Load must be balanced.

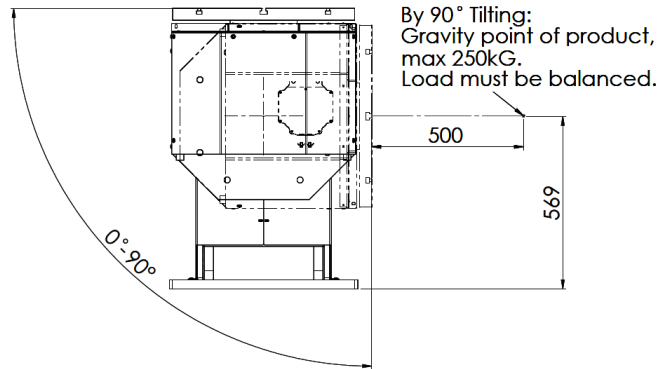

Flame Spray Technologies B.V.
The Netherlands (Head Office)
Tel: +31 26 3190140
Fax: +31 26 3190141
info@fst.nl

Flame Spray Technologies Ltd.
United Kingdom
Tel: +44 2921 660511
Fax: +44 2921 660811
infor@fst.nll

Flame Spray Technologies
France
Tel: +33 660 479051
info@fst.nl

Flame Spray Technologies
Spain
Tel: +34 608 986 570
info@fst.nl

Flame Spray Technologies, Inc.
United States
Tel: +1 616 9882622
Fax: +1 616 9882629
info@fstincusa.com

Flame Spray Technologies
Middle East
Tel: +971 4 347 2220
Fax: +971 4 347 2221
fstme@emirates.net.ae

Flame Spray Technologies Pte Ltd.
Singapore
Tel: +65 644 982 38
customer-support@fst-sg.com

